

PARTITION SYSTEMS

VISION PANELS

MIDDAS INTEGRATED | M100



TECHNICAL SPECIFICATION

VISION PANELS

MIDDAS INTEGRATED | M100

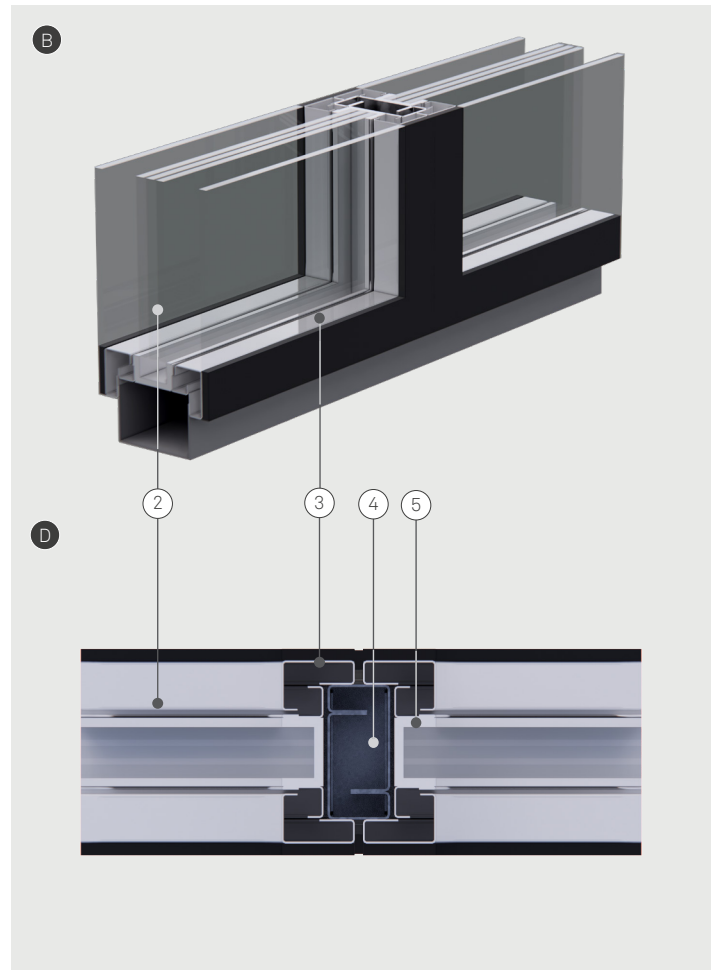
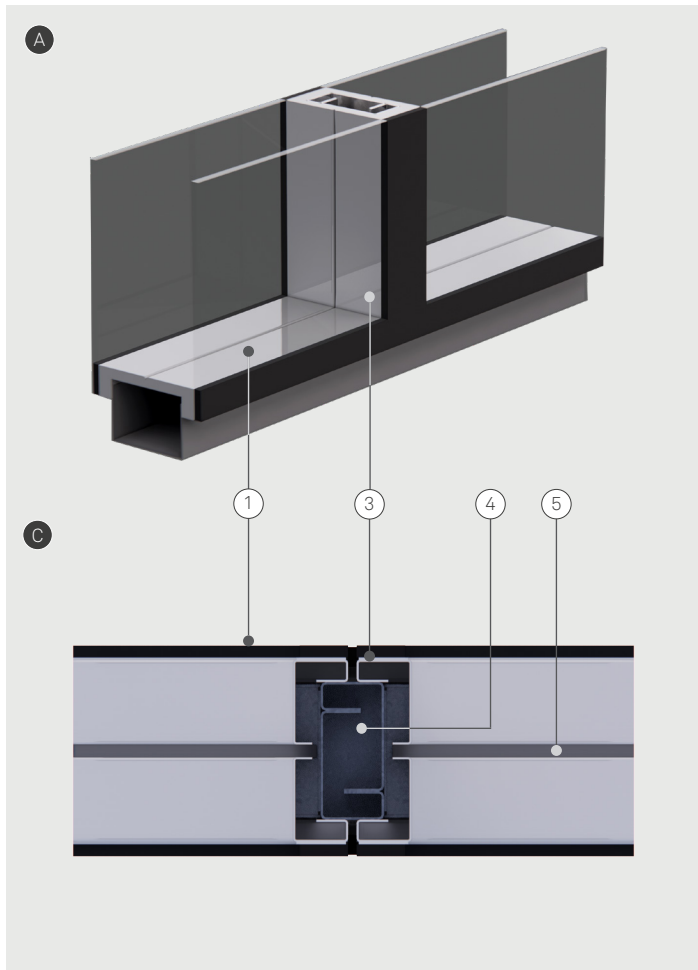

SPECIFICATION FEATURES

- Flush ledge-free vision panels and full height glazed partitions
- Fire rated or non fire rated glazing options with silver window reveal
- Recessed base for flush floor cove (full height option)
- Base track architectural shadow gap (full height option)
- Multiple panel lifts for large format glazing

LEGEND	
1	6mm CFT Glass
2	Fire Rated Glass
3	Glazing Frame
4	Vertical Stud Assembly
5	Glazing Seal
A	Vertical Section Through Glazed Wall (NFR)
B	Vertical Section Through Glazed Wall (FR)
C	Horizontal View (NFR)
D	Horizontal View (FR)

TECHNICAL SPECIFICATION

PANELS	
Dimensions	1000mm x 1000mm as standard (bespoke sizes on request)
Thickness	100mm
Lift	6000mm (multiple lifts) Full height glazing (multiple lifts; project specific)
Weight	36kg/m ² (complete glazing cassette with 6mm CFT glass including framework)
Assembly	Flush bonded to proprietary framework with 25mm black gloss screen printed border and silver internal reveals as standard
Glass Options	6mm Clear Float Toughened (CFT) as standard 6.4mm Laminated Fire Glass
Options	Encapsulated blinds Switchable smart glass Manifestations
PERFORMANCE	
Fire	EI 60 or EI 30 to BS 476-22
Acoustic	29dB to BS EN ISO 140-3:1995 (NFR) 49dB to BS EN ISO 140-3:1995 (FR)
Thermal (U-Value)	2.19W/m ² K (NFR)

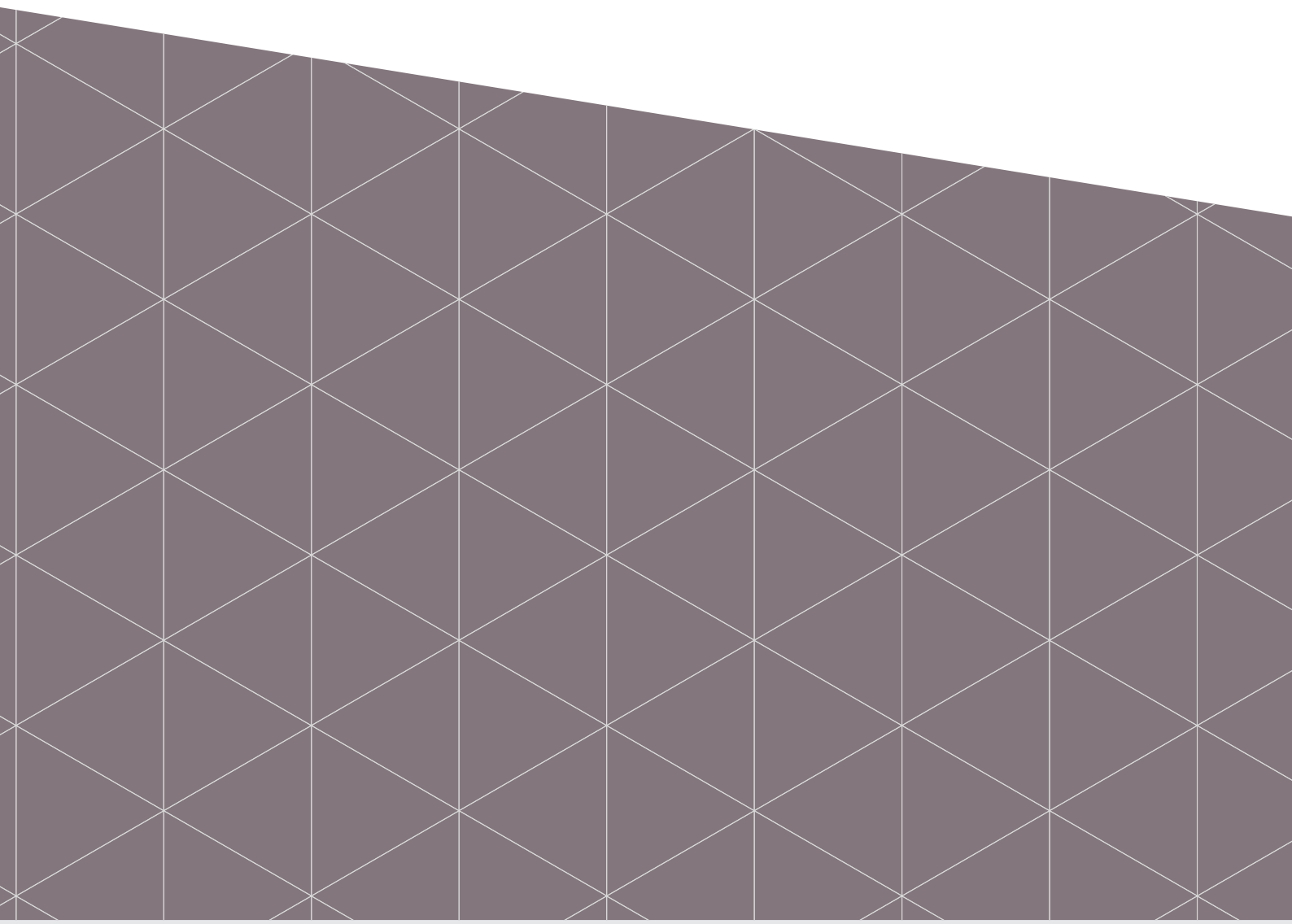

MIDDAS Interior Solutions Ltd

Units D1-D4, Halesfield 5, Telford, TF7 4QJ

01743 294 141 | info@middas.co.uk | www.middas.co.uk